



**OPEN
_FUTURE**

_MUSEUMS AND AI

*Keynote at the Innovation and Integrity -
Museums paving the way in an AI driven
society conference*

Paul Keller

MARCH 2024

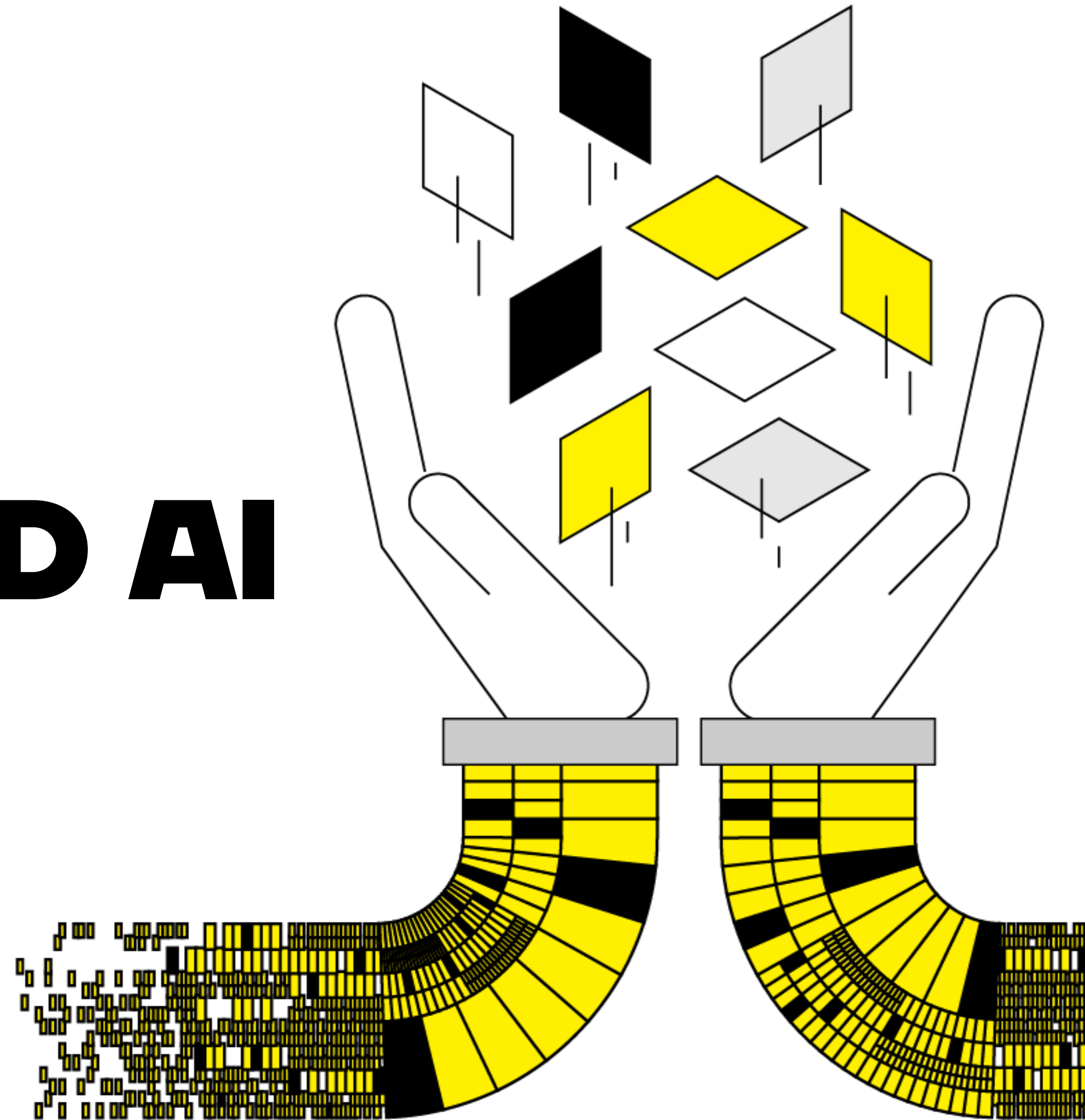

**AS A TECHNOLOGY, AI
HAS THE POTENTIAL
TO CHANGE HOW WE
PERCEIVE AND
UNDERSTAND THE
WORLD AROUND US.**

**THESE ARE NOT
MYSTIC MACHINES
BUT TOOLS DEPLOYED
BY SOME OF THE
BIGGEST AND MOST
POWERFUL PRIVATE
CORPORATIONS IN
THE WORLD AS A
MEANS TO GENERATE
PROFIT.**

1. MUSEUMS ARE PUBLIC INSTITUTIONS



MUSEUMS IN THE AI ACT

*For the purposes of this Regulation the notion of publicly accessible space should be understood as referring to any physical place that is accessible to an undetermined number of natural persons, and irrespective of whether the place in question is privately or publicly owned and irrespective of the activity for which the place may be used, such as [...] entertainment (for instance, cinemas, theatres, **museums**, concert and conference halls).*

— AI ACT, RECITAL 19



*(Non) prohibition of
real time remote
biometric identification*



MUSEUMS IN THE COPYRIGHT DIRECTIVE

Member States shall provide for an exception to the rights provided for in Article 5(a) and Article 7(1) of Directive 96/9/EC, Article 2 of Directive 2001/29/EC, and Article 15(1) of this Directive for reproductions and extractions made by research organisations and cultural heritage institutions in order to carry out, for the purposes of scientific research, text and data mining of works or other subject matter to which they have lawful access.

— ARTICLE 3(1) CDSM DIRECTIVE

2. MUSEUMS ARE TINY



211M

Works in the Pile

5B

*Image text pairs in
LAION 5B*

154M

*Objects in the
collections of the
Smithsonian
Institutions*

8M

*Objects in the
collection of the
British Museum*

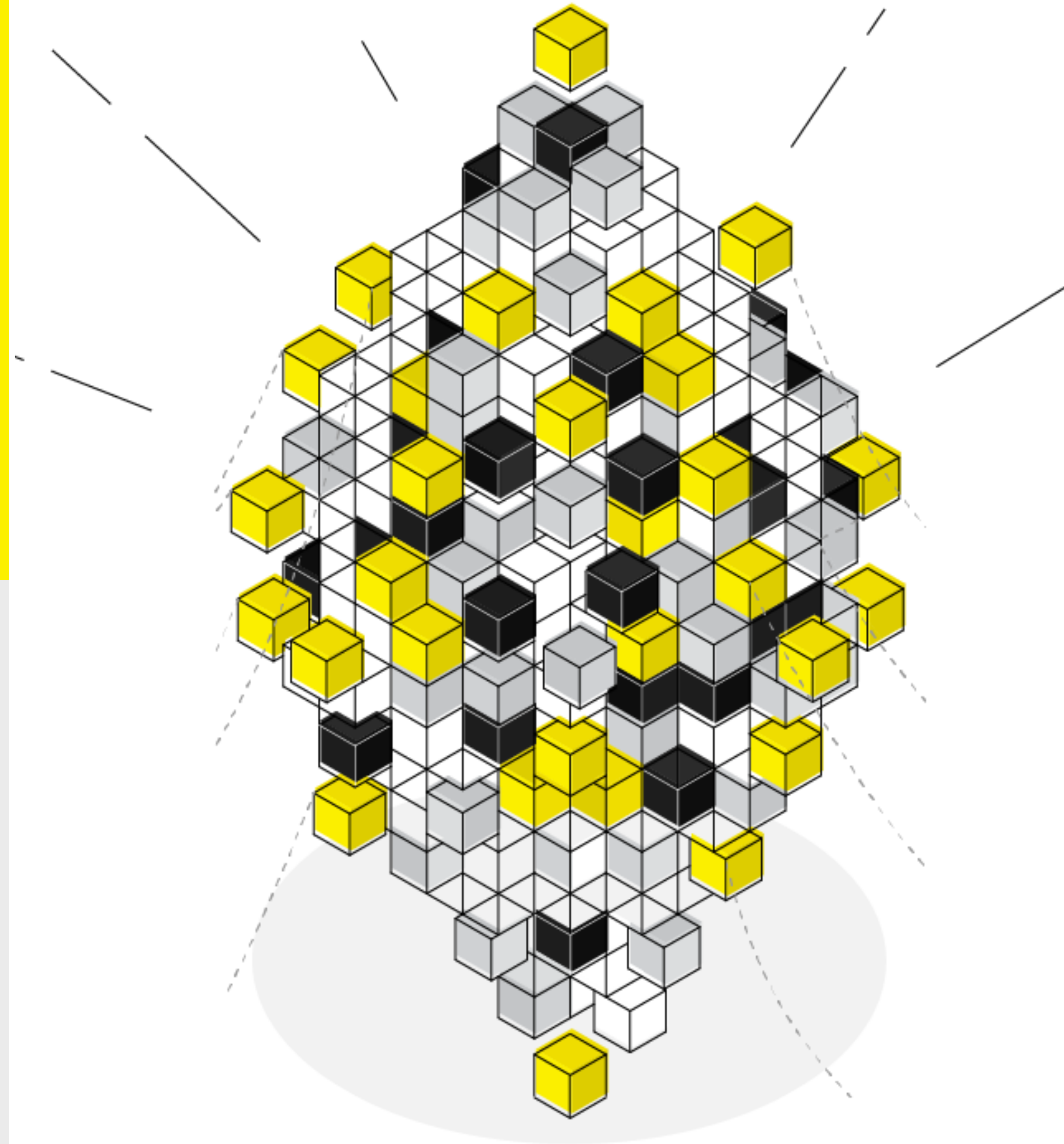

3 ■ MUSEUMS HELP US MAKE SENSE OF THE WORLD



BIAS



Sure, here are some images featuring diverse US senators from the 1800s:



 [Generate more](#)



BIAS

TRUTH

TRANSPARENCY IN THE AIA:

Providers of general purpose AI models shall:

*(d) draw up and **umake publicly available** a sufficiently detailed summary about the content used for training of the general-purpose AI model, according to a template provided by the AI Office.*

**– ART.53 (1) OBLIGATIONS FOR PROVIDERS
OF GENERAL PURPOSE AI MODELS**

4. MUSEUMS SERVE THE PUBLIC INTEREST



1. ACCESS TO KNOWLEDGE

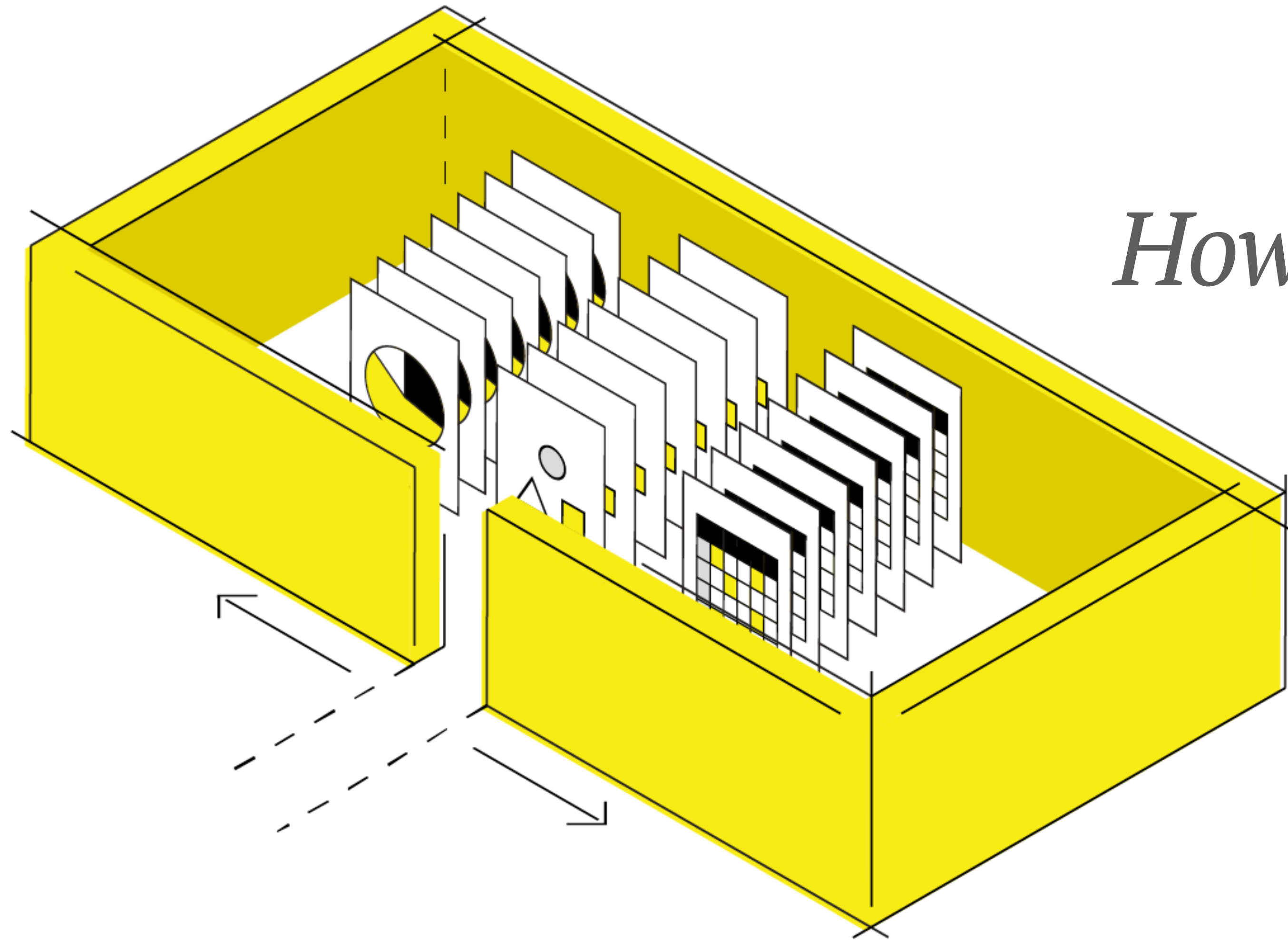

How can museums ensure sustainable access to collections ?

FOR HUMANS AND MACHINES



2. TRANSPARENCY

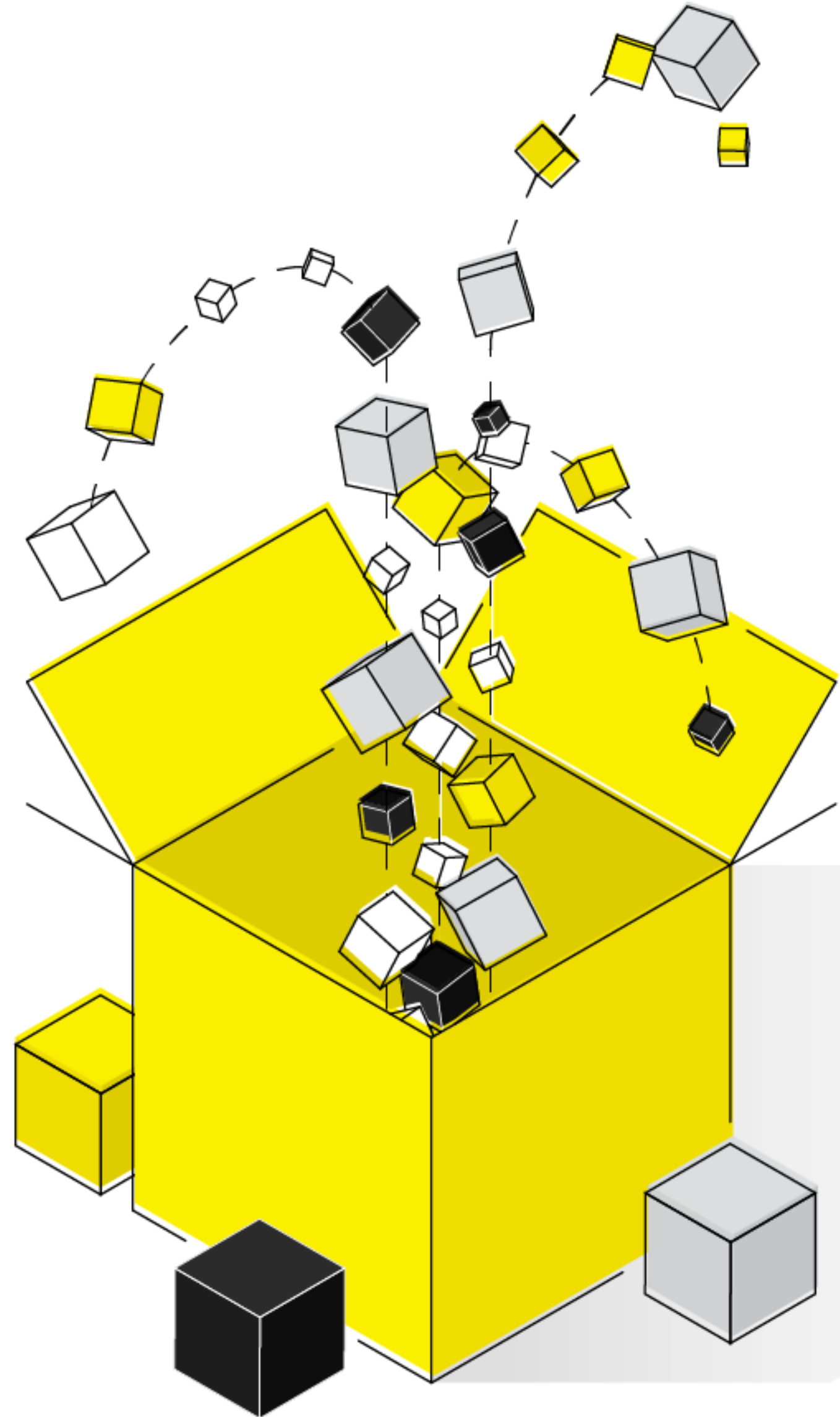

*Embrace the role of being
stewards of facts*

RESIST THE PULL OF AI SOLUTIONISM

3. DIGITAL PUBLIC INFRASTRUCTURE

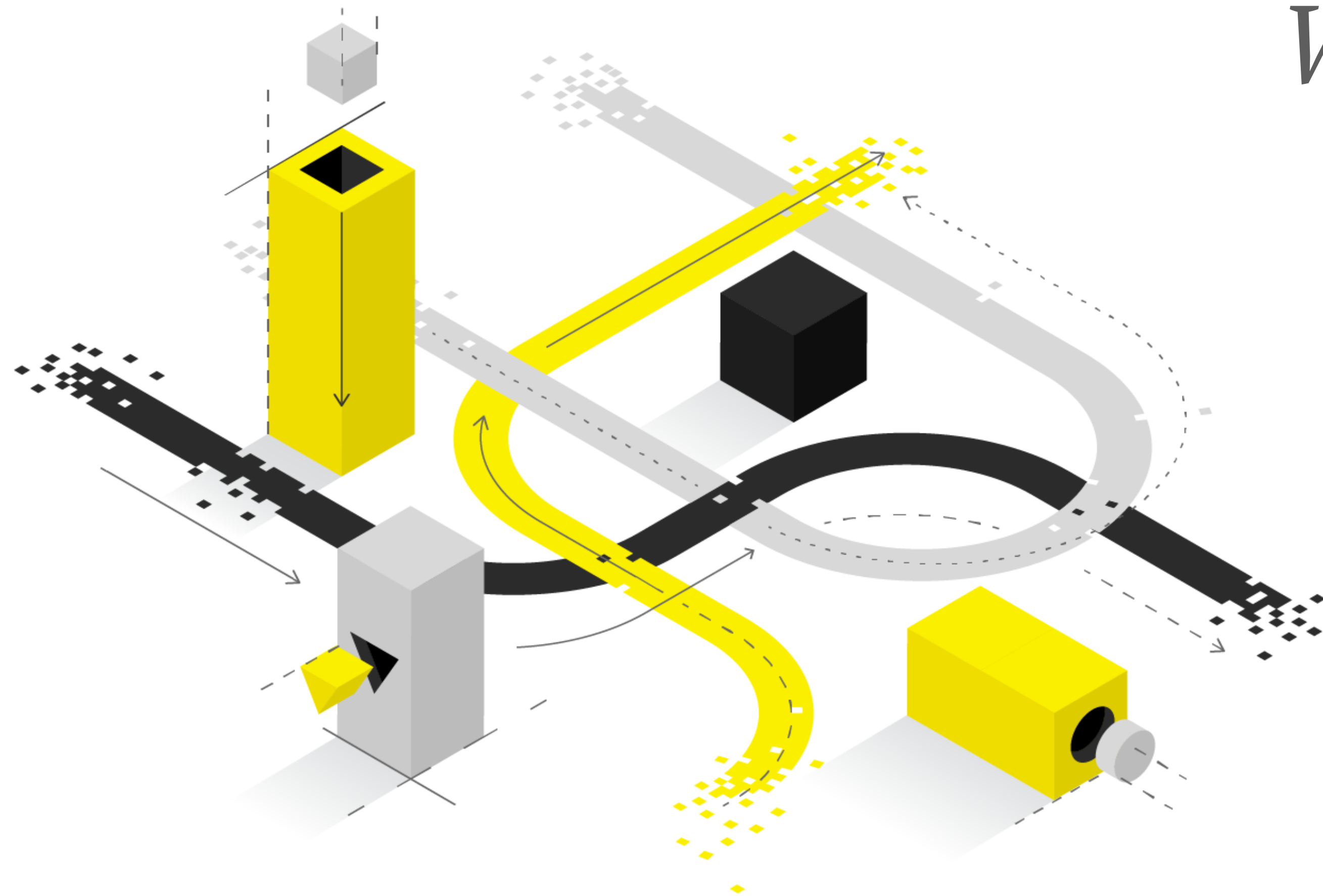

*We need to understand
museums as building
blocks of a European
public digital
infrastructure*

BEYOND DATA SPACES





**OPEN
_FUTURE**

_THANK YOU!

paul@openfuture.eu

WWW.OPENFUTURE.EU

